

FEATURES:

- 24VDC output
- 8 or 10 amp max total alarm current
- Class A or Class B outputs
- 115VAC 60Hz, 4.4 Amp
- Short circuit and thermal overload protection
- Built-in charger for sealed lead acid or gel type battery backup
- Maximum charge current 0.7 Amp
- Zero voltage drop upon transfer to battery backup
- AC input and DC output LED indicators
- AC fail supervision (form "C" contact rated 1 amp, 28VDC)
- Low battery and battery presence supervision (form "C" contact rated 1 amp, 28VDC)

EF-AL-NAC-802ULADA NAC Power Extender

Overview

Model EF-AL-NAC-802ULADA is an extremely cost effective 8 amp voltage regulated remote power supply/battery charger. It may be connected to any 12 or 24 volt Fire Alarm Control Panel (FACP). Primary applications include Notification Appliance Circuit (NAC such as strobes and horns) expansion support to meet ADA requirements. It also provides auxiliary power to support system accessories. The unit delivers regulated and filtered 24 or 12 volt power to Class B or Class A NAC loop circuits. Additionally, a separate 1.0A auxiliary output with reset for four (4)-wire smoke detectors is available. The 8 amp rated supply current can be divided between the four (4) outputs for powering NAC devices. Each output is rated at 2.5 amp max., and can be independently programmed for Steady, Temporal Code 3 or Strobe Synchronization. All outputs may be programmed for Input to Output Follower Mode (output will follow input. i.e. March Time Input, March Time Output). An individual output of 4 amp is achieved by paralleling 2 outputs. In non-alarm condition independent loop supervision for Class A and/or Class B FACP NAC circuits is provided. In the event of a loop trouble the FACP will be notified via the steered input (input 1 or input 2). In addition, there are common trouble output terminals (N.C., C, N.O.) which are used to indicate general loop/system trouble. A common trouble input is provided for optional NC (normally closed) devices to report trouble to the FACP. Two (2) FACP signaling outputs can be employed and directed to control supervision and power delivery to any combination of the four (4) outputs. The unit also features "Loop Output" trouble memory indication to help identify troublesome sporadic problems.

NOTE:

Refer to Installation manual for specific installation and product information, catalog sheet for reference only.

EF-NAC Series

Notification Appliance Control Power Supply



EF-AL-NAC-1042ULADA NAC Power Extender

Overview

Model EF-AL-NAC-1042ULADA is an extremely cost effective 10 amp voltage regulated remote NAC Power Extender. It may be connected to any 12 or 24 volt Fire Alarm Control Panel (FACP). Primary applications include Notification Appliance Circuit (NAC) expansion (supports ADA requirements) and will provide auxiliary power to support system accessories. The unit delivers regulated and filtered 24 or 12 volt power via up to four (4) Class B, four (4) Class A or combination of Class B and Class A Notification Appliance Circuits. Additionally, the unit can supply up to 1 amp from continuous AUX output and up to 1 amp from AC disconnected AUX output. The 10 amp rated supply current can be divided between the four (4) outputs for powering notification appliances and the AUX outputs. Each output is rated at 2.5 amp max (total not to exceed 10 amp), and can be independently programmed for Steady, Temporal Code 3 or Strobe Synchronization. All outputs may be programmed for Input to Output Follower Mode (output will follow input. i.e. March Time Input, March Time Output). An individual output of 4 amp is achieved by paralleling 2 outputs. In non-alarm condition units provide independent loop supervision for Class A and/or Class B FACP NAC circuits. In the event of a loop trouble the FACP will be notified via steered inputs (input 1 or input 2). In addition, there are common trouble output terminals (N.C., C, N.O.) which are used to indicate general loop/system trouble. A common trouble input is provided for optional NC (normally closed) devices to report trouble to the FACP. Two (2) FACP signaling outputs can be connected to power extender inputs. These inputs can then be directed to control supervision and power delivery to any combination of the four (4) outputs. The unit also features "Loop Output" trouble memory indication to help identify troublesome sporadic loop problems.

Multiple Power Supply interconnect wiring

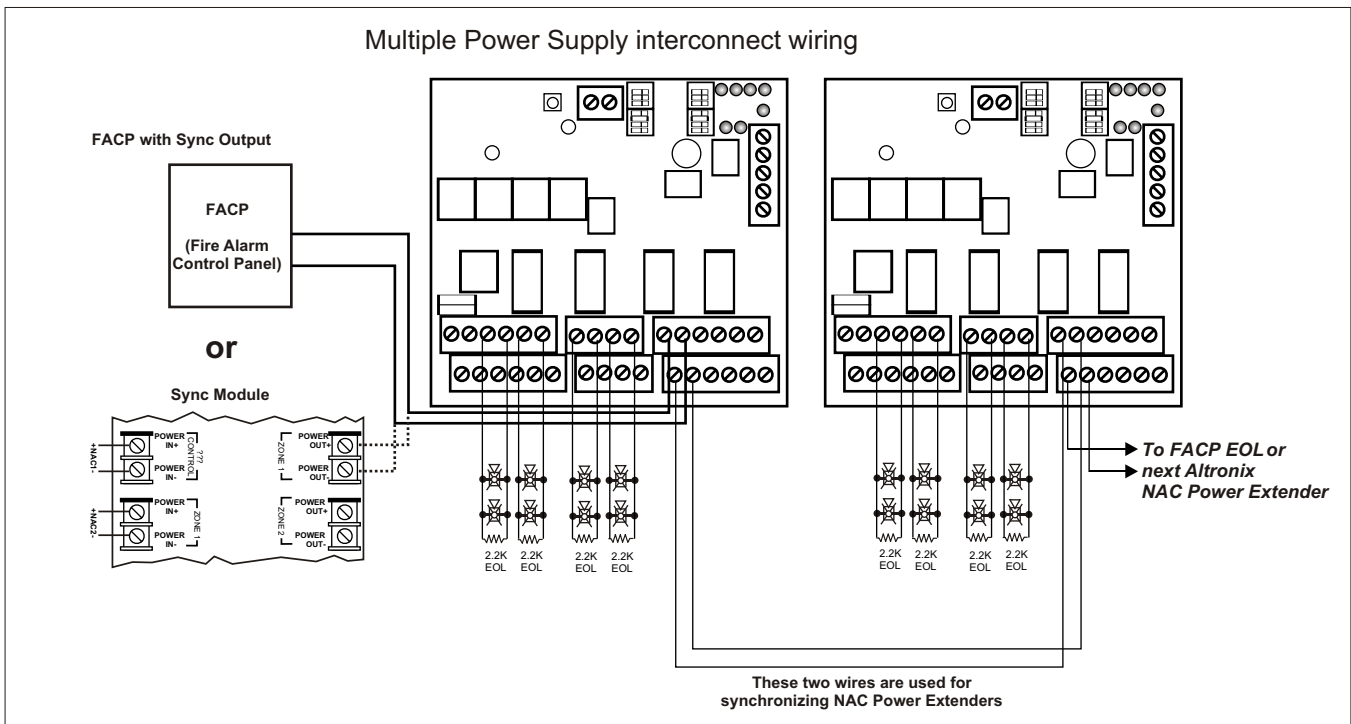

Class A wiring

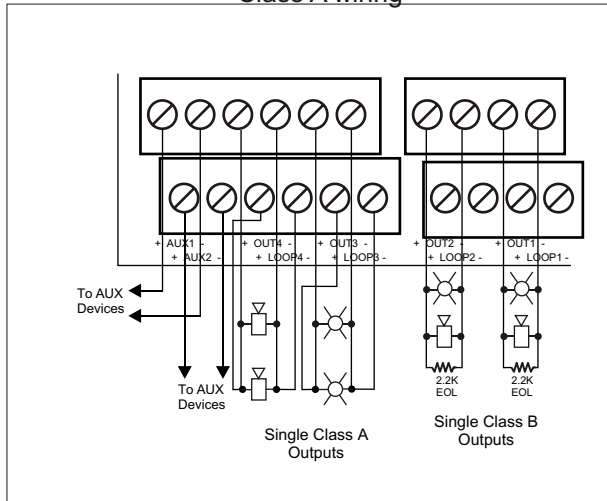

Class B Wiring

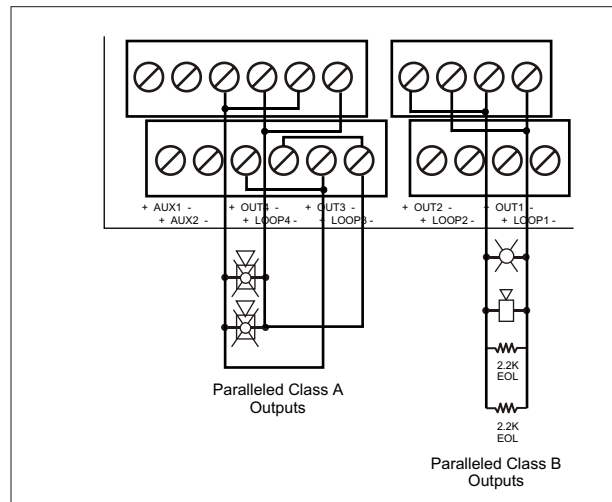

HOW to Order:

EF-AL-NAC-802ULADA

8 Amp NAC power Extender 2 Class "A" or 4 Class "B" outputs

EF-AL-NAC-1042ULADA

10 Amp NAC power Extender 4 Class "A" or Class "B" outputs

Engineering Specifications:

Notification Appliance Circuit Expander Power Supplies shall be capable of either 8 or 10 amps. Each Power supply shall be field selectable for either Class A or Class B output notification, where applicable the power supplies shall provide either 4 Class B or Class A circuits. The NAC power supplies shall have internal protocols build into the units and work in conjunction with Amseco, Faraday, Gentex Wheelock and System Sensor. In addition shall provide up to 1 Amp of auxiliary continuous output power. The NAC power extenders shall be either Evax EF-AL-NAC-802ULADA or EF-AL-NAC-1042ULADA.

Specifications are subject to change without notice. Specifications are provided for information only and no responsibility is assumed by Evax Systems, Inc. for their use.